

KITCHEN EXTRACTORS

K Series



CK-25 N



CK-35 N



CK-40 F



CK-50



CK-60 F



ECO-500

Range of centrifugal extractors specifically designed for the extraction of moist, grease laden air and fume from under domestic cooker canopies. This range consists of six models with airflow ranging between 250 and 625 m³/h. All the models are fitted with single phase motors.

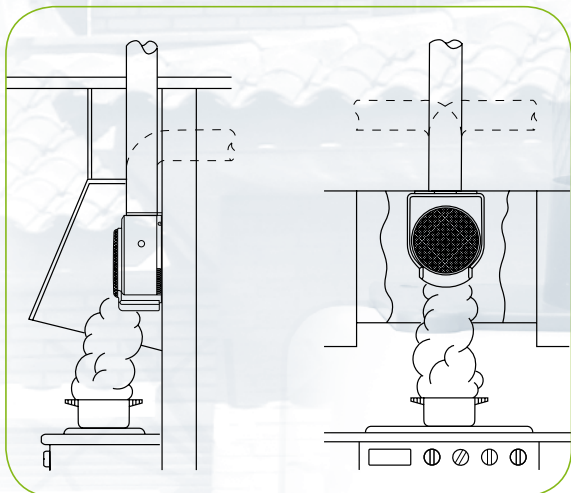

To obtain the maximum efficiency of the polluted air extraction, the K series fans should be installed within a cooker canopy. The airflow required depends upon the canopy width and the distance between the canopy and the cooker. The K series fans should be installed in vertical position with the grease collection tray at the bottom.



Kitchen free of smokes, odours and grease laden air



Without S&P



With S&P

The efficiency and of the kitchen extractors depends on the maintenance and cleaning of the centrifugal impeller. All the S&P extractor parts are easily removable and can be cleaned in the dishwasher.

ORIENTATIVE CHART TO CHOOSE THE MOST SUITABLE EXTRACTOR FOR KITCHENS WITH CANOPIES WITHIN THE WALL

CANOPY SIZE	RECOMMENDED AIRFLOW (m ³ /h)	EXTRACTION DUCT LENGTH (*)		
		0 to 5 m	5 to 15 m	15 to 30 m
UNTIL 60 cm	200-300	CK-25 N	CK-35 N CK-40 F	CK-40 F CK-50 ECO-500
		CK-35 N CK-40 F CK-50 ECO-500	CK-40 F CK-50 ECO-500 CK-60 F	CK-50 ECO-500 CK-60 F

(*) Expected with an installation with two 90° elbows.



KITCHEN EXTRACTORS

K Series (Plastic range)



CK-25 N



CK-40 F



CK-60 F



0 027382 603070

Centrifugal extractors manufactured from flame retardant plastic V0. All extractors are class II insulation fitted with centrifugal impeller and single phase 230V 50Hz speed controllable motor. This range consists of three models with airflow ranging up to 625 m³/h.

CK

Kitchen extractors

Extractors can be dismantled



Extractor parts easily removable for cleaning in the dishwasher

Metallic Teflon coated filter



Fitted to the inlet to prevent the build-up of grease within the fan and ducting enclosure (CK-40F and CK-60F)

Protection guard



To avoid any contact with the impeller (CK-25N)

Removable grease collection tray



To collect the grease. Easily removable for cleaning

CK-60F: 2-speed motor



REGUL-2 speed selector I/II switch to adapt the extract air volume to the needs

Model features

	CK-25 N	CK-40 F	CK-60 F
Grease collection tray	•	•	•
Protection guard	•		
Metallic Teflon coated filter		•	•
Removable	•	•	•
Washable in a dishwasher	•	•	•
Adjustable	•	•	•
2 speed			•

Technical characteristics

Model	Speed (r.p.m.)	Abs. power at free discharge (W)	Voltage (V) 50 Hz	Airflow at free discharge (m ³ /h)	Sound pressure level (dB(A))	Weight (kg)
CK-25 N	2250	40	230	250	50	1,9
CK-40 F	2350	70	230	360	55	2,7
CK-60 F	VR	160	230	625	59	4,7
	VL	96		415	54	

Performance curves

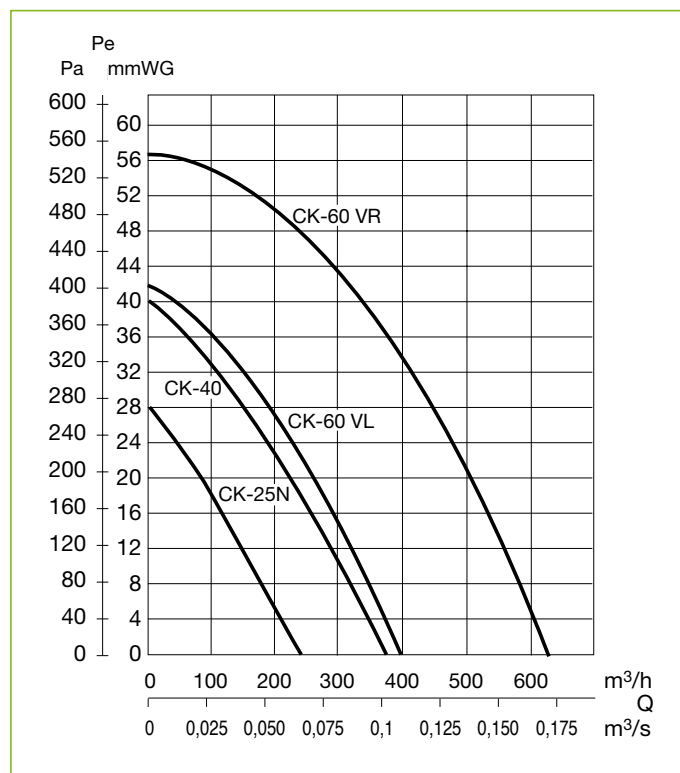

Dimensions (mm)

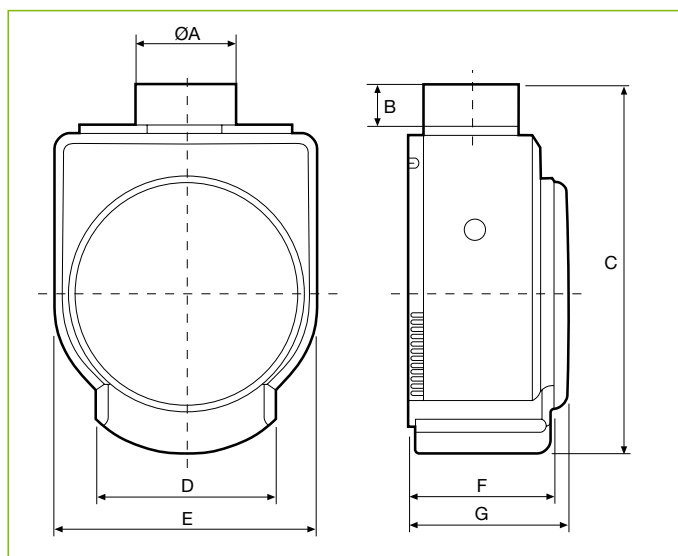

Model	ØA	B	C	D	E	F	G
CK-25 N	98	34	304	149	218	-	127
CK-40 F	98	42	370	179	266	140	162
CK-60 F	116,5	42	362	180	293,5	145	174



Accessories

Accessories	CK-25 N	CK-40 F	CK-60 F
 GSA Flexible aluminium ducting	GSA-100	GSA-100	GSA-125
 CX Worm drive clips	CX-80/125	CX-80/125	CX-125/215
 PER-W Backdraft shutters	PER-100 W	PER-100 W	PER-125 W
 CAR Backdraft shutters	CAR-100	CAR-100	CAR-125
 CM-130 Backdraft shutters			CM-130

Accessories	CK-25 N	CK-40 F	CK-60 F
 GRA Aluminium guards	GRA-70	GRA-70	GRA-100
 CT Cowl	CT-125	CT-125	CT-125
 PF-60 Filter panel	PF-60	PF-60	PF-60
 REB Single phase electronic fan speed control regulators	REB-1N REB-1NE	REB-1N REB-1NE	REB-1N REB-1NE
 Regul-2 Two speed selector switch			REGUL-2

CK Kitchen Exhaust Fan Kits

CK Plastic range

Are fitted with all the elements (extractor and accessories) needed to carry out a successful installation.



Kit CK-40 F

- Includes:**
- 1 CK-40F fan
 - 3 m of GSA-100 flexible aluminium ducting
 - 2 duct connectors CX-80/125
 - 1 backdraft shutter CM-130



Kit CK-60 F

- Includes:**
- 1 CK-60F fan
 - 3 m of GSA-125 flexible duct
 - 2 duct connectors CX-125/215
 - 1 backdraft shutter CM-130
 - 1 two speed switch REGUL-2

KITCHEN EXTRACTORS

K Series (Metallic range)



CK-35 N



CK-50



ECO-500



Centrifugal extractors manufactured from sheet steel with an epoxy polyester paint finished. All extractors are fitted with centrifugal impeller and single phase 230V 50Hz speed controllable motor. This range consists of three models with airflow ranging up to 480 m³/h.

Protection guard



To avoid any contact with the impeller

Removable grease collection tray



To collect the grease. Easily removable for cleaning

Extractors can be dismantle



Extractor parts easily removable for cleaning in the dishwasher

Model features

	CK-35 N	CK-50	ECO-500
Grease collection tray	•	•	•
Protection guard	•	•	•
Metal filter	•	accessory	accessory
Removable	•	•	•
Washable	•	•	•
Adjustable		•	•

Technical characteristics

Model	Speed (r.p.m.)	Abs. power at free discharge (W)	Voltage (V) 50 Hz	Airflow at free discharge (m ³ /h)	Sound pressure level (dB(A))	Weight (kg)
CK-35 N	2000	125	230	350	56	3,2
CK-50	1050	120	230	480	52	3,5
ECO-500	1050	90	230	480	52	3,5

Performance curves

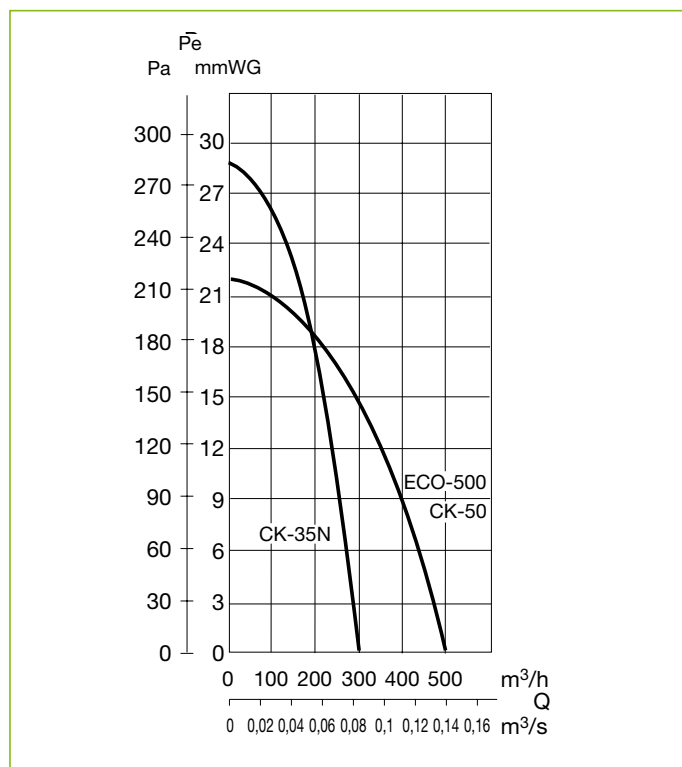

Dimensions (mm)

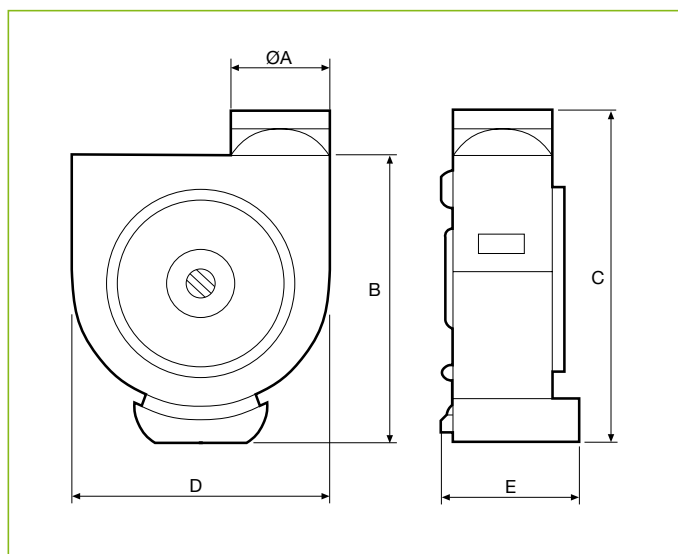

Model	ØA	B	C	D	E
CK-35 N	110	292	337	230	130
CK-50	115	315	375	315	132
ECO-500	115	315	375	315	132

Accessories

Accessories	CK-35 N	CK-50	ECO-500
GSA Flexible aluminium ducting	GSA-125	GSA-125	GSA-125
CX Worm drive clips	CX-125/215	CX-125/215	CX-125/215
PER-W Backdraft shutters	PER-125 W	PER-125 W	PER-125 W
CAR Backdraft shutters	CAR-125	CAR-125	CAR-125
CM-130 Backdraft shutters	CM-130	CM-130	CM-130

Accessories	CK-35 N	CK-50	ECO-500
GRA Aluminium guards	GRA-100	GRA-100	GRA-100
CT Cowl	CT-125	CT-125	CT-125
PF-60 Filter panel	PF-60	PF-60	PF-60
REB Single phase electronic fan speed control regulators	REB-1N REB-1NE	REB-1N REB-1NE	REB-1N REB-1NE