



Single room heat recovery unit provides an energy efficient through-the-wall ventilation solution with a tubular heat exchanger to enable the renewal of the air in a dwelling or commercial setting. Heat recovery performance of up to 75% (150mm model). The 100mm diameter model can replace existing bathroom extract fans. Designed for continuous operation, the balanced extract and supply airflow is proportional to humidity levels and this ensures excellent indoor air quality.

Construction features

- DC motors.
- Efficient centrifugal impellers.
- Tubular heat exchanger.
- Unique humidity proportional airflow.
- Automatic summer mode.
- Manual boost facility.
- Automatic frost protection.

Specific applications

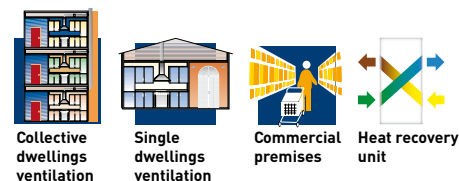

Maintenance and cleaning
 Easy access.



Tubular heat exchanger
 100 or 150 mm.

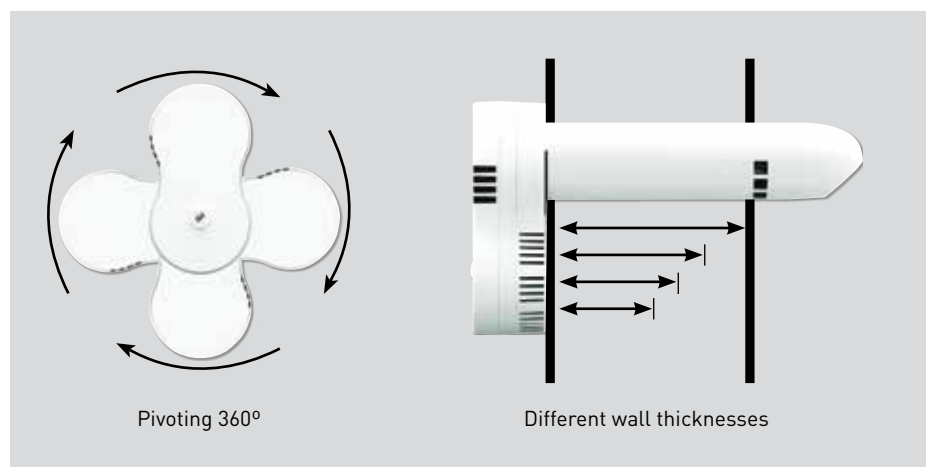

Fitting alternatives

TECHNICAL CHARACTERISTICS

Model	Ø (mm)	Wall (mm)	Voltage (V)	Minimum airflow (m³/h)	Absorbed power (W)	Sound pressure level (dB(A))	Electric scheme*	Boost (m³/h)	Absorbed power (A)	Sound pressure level (dB(A))	Maximum performance (%)
100/310	100	310	230	25	4,9	22	45	45	20,4	39	68
100/430		430			5,2	22					
100/500		500			5,2	22					
100/600		600			5,8	23					
150/310	150	310	230	25	4,6	23	45	45	14,9	36	75
150/430		430			4,9	24					
150/500		500			4,7	22					
150/600		600			5,1	23					

100/310-12V	100	310	12	25	4,9	22	45	45	20,4	39	68
100/430-12V		430			5,2	22					
100/500-12V		500			5,2	22					
100/600-12V		600			5,8	23					
150/310-12V	150	310	12	25	4,6	23	45	45	14,9	36	75
150/430-12V		430			4,9	24					
150/500-12V		500			4,7	22					
150/600-12V		600			5,1	23					

* See section Electric Schemes.

DIMENSIONS (mm)

